

SÜDMO TANKTOP PROTECT AND CLEAN



TANKTOP GAS, CLEANING AND SAFETY FITTINGS

PRODUCT INFORMATION

Operating a tank in the food, beverage, pharmaceutical, and cosmetics industries requires adherence to process, safety and hygiene standards. One of the process related challenges comes when adding or removing carbon dioxide, fermentation gases or nitrogen blanketing while ensuring optimal cleaning. The tank must also be protected from damage caused by overpressure or vacuum.

Pentair Südmö's TankTop fitting offers a proven simple and reliable compact system that allows the addition and removal of gases and CIP cleaning fluid using one process connection. Tanktop fittings, up to a certain diameter, can have the safety valve directly connected to the unit to protect against overpressure and the vacuum valve directly connected to protect against vacuum. This option, in many applications, eliminates the expense of a tank dome plate. In addition, optimal cleaning of the complete system and the additional safety fittings is assured.

Correctly designing the process for the air cleaning combination depends on many factors that must be calculated for each tank or application. Information such as diameter, compressive strength and process parameters must be clearly specified in advance. Customers can use the detailed form on page four to provide the needed information.

ADVANTAGES

- Compact system
- Flexible with customizable executions
- Cost effective proven technology
- No automation required
- No additional cleaning piping
- Cleanable and self-draining
- Easy to install and maintain
- Meets all safety requirements

TECHNICAL INFORMATION

NOMINAL DIAMETERS

DN 50 to DN 150 (with regard to fittings)

MATERIAL

Stainless steel:

1.4301 [AISI 304]
1.4307 [AISI 304L]
1.4404 [AISI 316L]

OPERATING TEMPERATURES AND PRESSURES

Available upon request

SURFACES

Product contact

Ra ≤ 0.8 µm

Non-product contact

Ra 1.6 µm

CONNECTIONS

Pipe connections in accordance with
- DIN 11850 Range 2 (DIN 11866 Range A)

FUNCTION

1. Overpressure protection

In the event of gas venting being blocked or closed off, the maximum strength of the tank can be exceeded under various operating conditions such as filling, overfilling, fermentation, or chemical reactions, which can lead to an explosion.

A spring-loaded safety valve, manufactured and verified in accordance with pressure equipment guidelines, is part of the fitting and protects against overpressure.

2. Vacuum protection

Draining, leaking, chemical reactions, content cooling, or vapor condensation can cause the tank pressure to drop below the minimum if the gas supply or ventilation is blocked or closed off, which can lead to implosion.

A spring-loaded or weight-loaded vacuum valve is part of the fitting and protects against vacuum.

3. Cleaning

The sliding seat (switchover without separate control) closes automatically when fluids hit it, so that the CIP fluids can flow through the spray tube and spray ball. The spray ball cleans the inside of the tank, while holes in the spray pipe enable cleaning inside the fittings.

For optimal tank cleaning, various equipment is used:

- Spray ball (diameter, flow rate and spraying angle adjusted to fit tank size)
- Rotation cleaner for larger tanks to reduce the flow rate of cleaning agents

4. Aeration and ventilation

The sliding seat is opened by a spring to allow gas to flow into or out of the tank for pre-tensioning, draining, releasing, or filling.

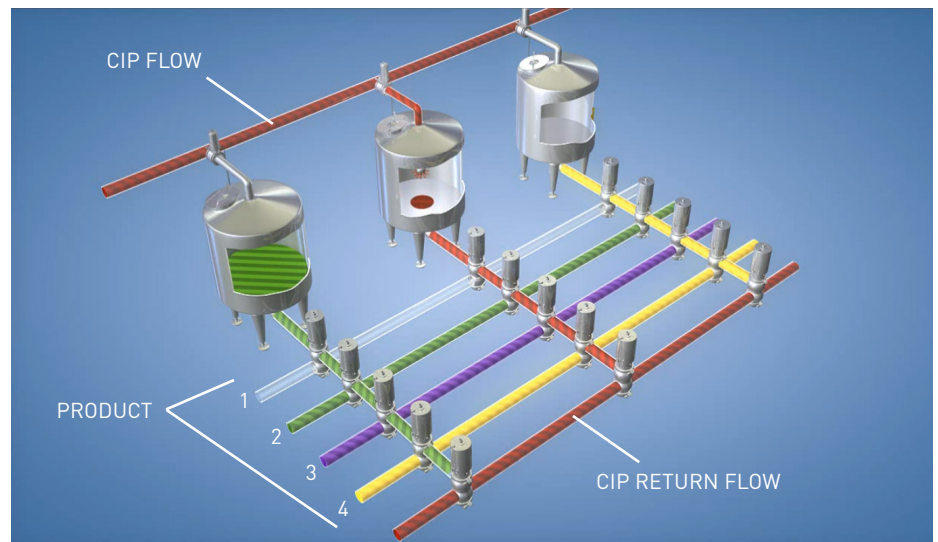

GREEN: TANK IS BEING FILLED

YELLOW: TANK IS BEING EMPTIED

RED: TANK IS BEING CLEANED

-> GAS VENTING

-> GAS SUPPLY OR VENTILATION

-> SUPPLY OF CLEANING FLUIDS (CIP MEDIA)

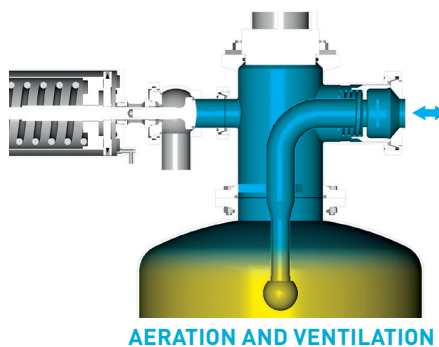
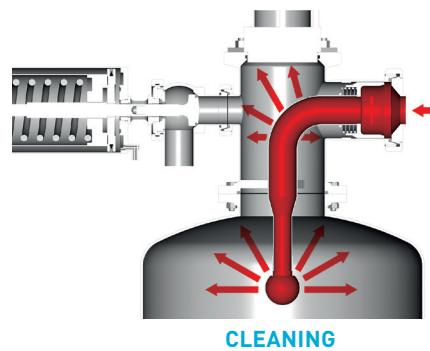

COMMENTS AND NOTES

Safety and vacuum valves are not process valves and serve only to protect the tank. Additional valves must be considered if further process functions are required.

It is generally recommended that safety and vacuum valves are fitted with a pneumatic lifting device to prevent germs and bacteria from settling in production areas.

Safety and vacuum valves must be heated under specific environmental conditions. Tank designs with safety or vacuum valves larger than DN 100 require the valves to be separately fitted to the dome plate.

TANKTOPS DESIGN FORM

Tank: Vertical Horizontal

Tank type: ZK fermentation tank ZK storage tank
 Pressure tank Other
 Tank with stirring unit etc.

Tank diameter: m

Tank height: m (total)
 m (cylindrical section) m (conical section)

Tank contents: m³

Filling rate: m³/h

Draining rate: m³/h

Nominal diameter of tank outlet (DN): mm

Nominal diameter of tank riser to TankTop (DN): mm (if already present)

Maximum allowable operating pressure: bar pressure

Safety valve set pressure: bar pressure

Allowable vacuum: mbar or mm WG

Maximum cleaning temperature: °C

Cleaning agent flow capacity: m³/h (if CIP pump is already present)

Minimum rinsing water temperature: °C (cold)

Safety valve pneumatic lifting device: yes no

Vacuum valve pneumatic lifting device: yes no

Risk of fitting freezing (heating required): yes no

Tank blanketed in the event of CIP CO₂: yes no

Tank outlet: free outlet
 tightly piped

Is the tank dome plate also being provided: yes no

Outer diameter of tank dome plate: mm

Thickness of tank dome plate: mm

Diameter of bolt hole for dome flange bore: mm

Diameter of boreholes for flange bolts: mm

Please list here any additional equipment required, such as sight glasses, lighting, level sensors, pressure sensors, rotation cleaners, rotation sensors etc.:

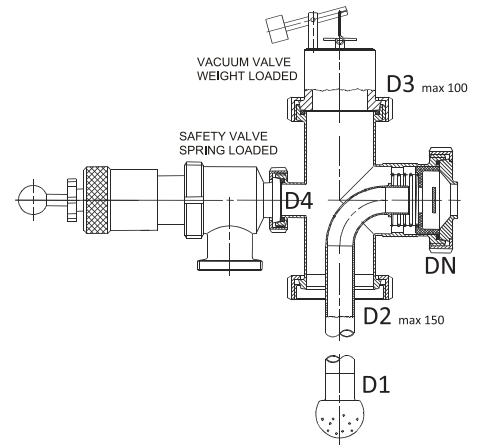

Company name: Name:

Telephone number: Email address:

Please send the completed form via email to INFO.SUEDMO@PENTAIR.COM or via fax to +49 9081 803 158. A staff member will contact you.



SÜDMO COMPONENTS GMBH

INDUSTRIESTRASSE 7, 73469 RIESBÜRG, GERMANY WWW.SUEDMO.DE

All Pentair trademarks and logos are owned by Pentair. All other brand or product names are trademarks or registered marks of their respective owners. Because we are continuously improving our products and services, Pentair reserves the right to change specifications without prior notice.

Pentair is an equal opportunity employer.

TankTop E-1/13 © 2013 Pentair - All Rights Reserved